

place blocks of wood under the bottom of the bottle to prevent superheating. A stirring device on the bath is very desirable.

Some water will expand from the sample bottle into the bulb, B. Any desired amount of vacuum may be produced by lowering the leveling bulb containing mercury attached to the bottom of the pipet at L. If any water accidentally enters the gas pipet, G, the mercury may be lowered until the water is drawn into the reservoir, W. Stopcock, S2, is then turned so that the by-pass, T, is open and the gas forced through, O, into a storage pipet or buret. Then the mercury is lowered until it reaches stopcock, S2, again, which is then turned so that as the mercury is raised again the water from W floats on top. It is carefully raised until the bend, K, is reached where the water flows back into the condenser tube. Before attempting this operation the collected gas already extracted must be removed as described.

After all gases have been removed from the sample, the water in bulb, B, is boiled for a couple of minutes to remove any gases present and then the stopper, Z, is loosened. By lowering the leveling bulb, the gas in the condenser tube and bulb is drawn over into the pipet, water entering the system through hole H. The bend, K, and the joint between the condenser tube and the capillary tube, E, enables one to make a clean separation of the gas and water. It was found that if a simple bend was used some gas always remained at the top of the bend.

Summary

A modification of the usual apparatus for removing dissolved gases in water has been described.

SEATTLE, WASHINGTON

[CONTRIBUTION FROM RESEARCH DEPARTMENT, NATURAL PRODUCTS REFINING COMPANY]

A METHOD FOR DETERMINING THE TENSILE STRENGTH OF GELATIN JELLIES

By A. ROSINGER AND J. J. VETTER

RECEIVED JULY 25, 1927

PUBLISHED DECEMBER 10, 1927

Up to the present time the only scientific method for determining jelly strength has been by the use of the Sheppard torsion dynamometer.¹ This apparatus is used for testing the jelly strength of glues and gelatins by the pure shear of moulded cylindrical test pieces.

The following method, first suggested by A. Rosinger in 1923, depends on the static loading of jelly membranes, and is based on the fact that a circular elastic membrane supported rigidly at its circumference and subjected to air pressure on one side assumes a spherical form.

¹ (a) Sheppard and Sweet, *THIS JOURNAL*, **43**, 539 (1921); (b) Sheppard, Sweet and Scott, *J. Ind. Eng. Chem.*, **12**, 1007 (1920).

When the wall thickness d' of a spherical surface is small compared to the radius r of the sphere, and the pressure within is p , the tensile stress (see any textbook on strength of material)

$$\sigma = \frac{pr}{2d'} \quad (1)$$

If we know the radius a of the frame holding the jelly membrane—a constant for the apparatus—and the height h of the spherical segment, the radius r of the sphere is

$$r = \frac{a^2\pi h^2}{2h} \quad (2)$$

There is no change in volume when a gel undergoes extension,² therefore by measuring the original thickness d of the jelly membrane the actual thickness d' for any radius up to the breaking point can be determined from the equation

$$d' = \frac{a^2\pi d}{\pi(a^2 + h^2)} = \frac{a^2d}{a^2 + h^2} \quad (3)$$

By substituting the values of r and d' from Equations 2 and 3 in Equation 1, we obtain

$$\sigma = p \frac{1}{4} \frac{1}{a^2d} \cdot \frac{(a^2 + h^2)^2}{h} \quad (4)$$

and letting

$$\frac{1}{4} \frac{1}{a^2d} = c \text{ and } \frac{(a^2 + h^2)^2}{h} = x$$

the tensile stress becomes

$$\sigma = cpx \quad (5)$$

The experimental data necessary for the determination of the tensile strength are

original membrane thickness	d
volume of spherical segment	V
pressure on membrane	p

The surface elongation is

$$E = \frac{\pi(a^2 + h^2) - \pi a^2}{\pi a^2} = \frac{h^2}{a^2} \quad (6)$$

and the linear elongation is

$$\epsilon = \frac{l' - l}{l} = \frac{\sqrt{\pi(a^2 + h^2)} - \sqrt{\pi a^2}}{\sqrt{\pi a^2}} \quad (7)$$

Fig. 1 shows V , ϵ and x as functions of h .

The value d may be conveniently measured with a microscope by attaching a scale to the adjusting screw and focusing on the upper and lower surfaces of the membrane, and the height h of the spherical segment may be obtained from the volume of the latter, instead of by direct measurement. See Fig. 1.

² Bogue, "Colloidal Behavior," McGraw-Hill Book Co., New York, 1924, Vol. 1, p. 412.

The apparatus, Fig. 2, consists of three parts: A, the bell for holding the membrane, fitted with a two-way stopcock; B, the buret with the manometer tube; and C, the reservoir for adjusting the total amount of air in the system to a definite volume.

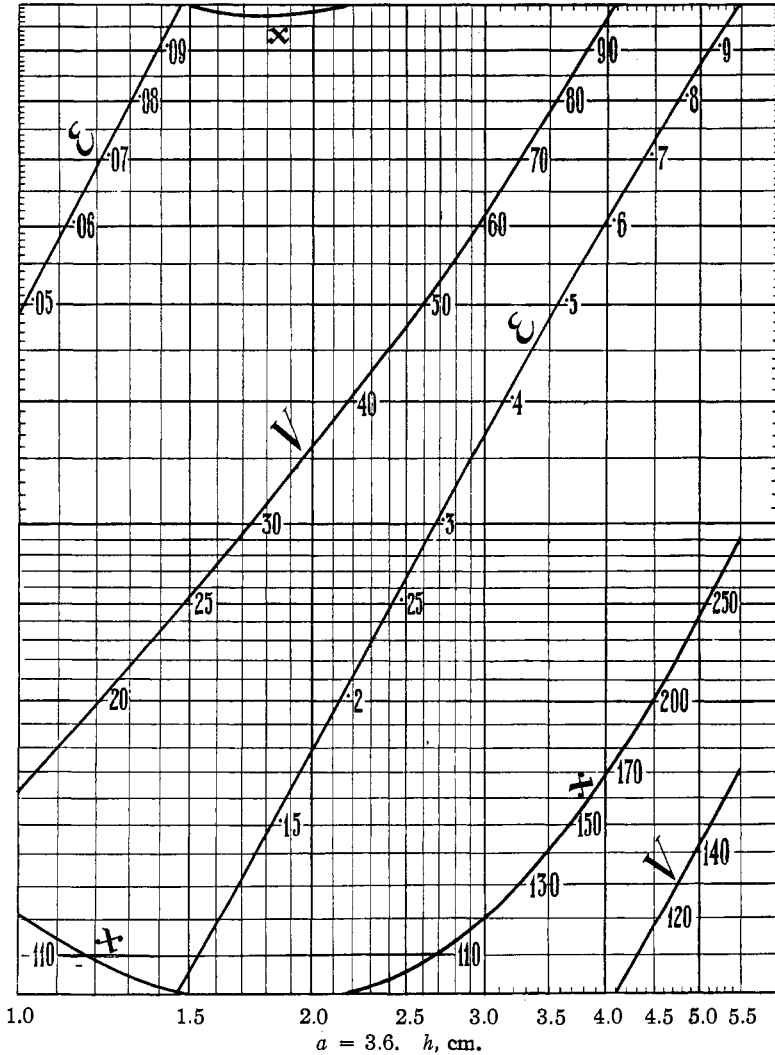

Fig. 1.

Experimental Part

The bell A is placed on a mercury surface and the gelatin solution poured in through the neck. After standing a definite time to set, the stopcock tube is attached to the bell and the latter shut off from the outside

air while being attached to the apparatus. The water level in C is adjusted to give a definite volume of air in the apparatus (1 liter) and water is run into the buret from a bottle above the apparatus to the zero point. The two-way stopcock attached to the bell is next turned to connect the latter with the apparatus and seal off the outside air. Water is run into

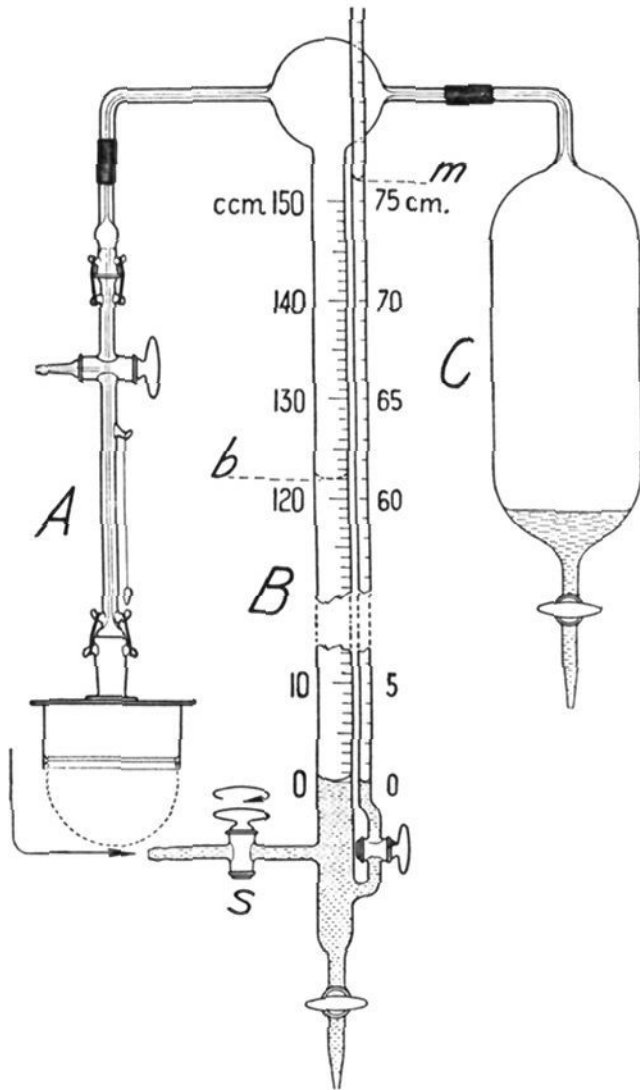

Fig. 2.

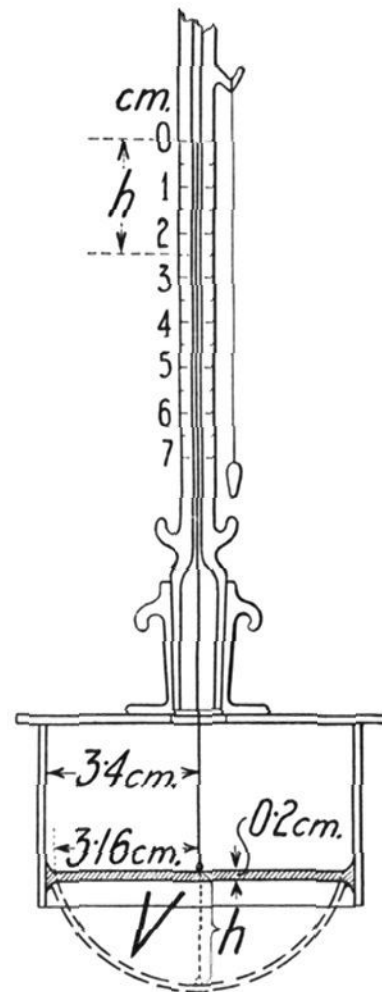

Fig. 3.

the buret through the stopcock S in 5cc. or 10cc. portions at a time and buret and manometer readings are taken after each addition. In releasing the pressure on the membrane, water is run out of the buret from the stopcock at the bottom in small portions at a time and buret and manometer readings are again taken. If a test is to be run over a considerable period of time, a beaker containing a small amount of water may be placed under the bell A to check evaporation from the membrane surface.

All membranes in the following tests were made from gelatin solutions prepared by soaking dry gelatin in cold water for fifteen minutes, heating

to 60° for five minutes and filtering. They were tested at 22 to 24° after standing for twenty hours.

To determine experimentally the value of a the arrangement shown in Fig. 3 was set up, using a very fine glass filament resting in the center

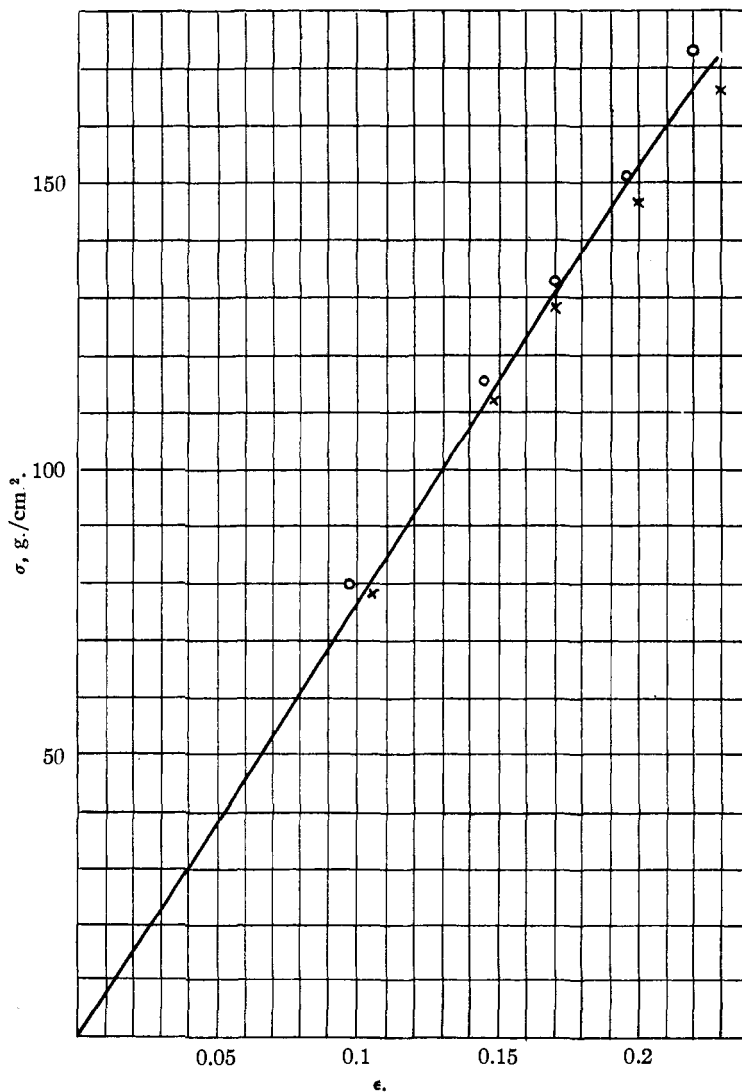

Fig. 4.

of the membrane and measuring the distance between the original and final positions in the graduated tube to find h , from which the value of a was calculated (see Table I).

TABLE I
DETERMINATION OF THE VALUE *a*

Eastman gelatin, P 1099; 20% jelly; 24 hours' setting; room temperature; *d* = 0.2 cm.

<i>b</i>	<i>m</i>	<i>h</i> , cm.	<i>p</i> , g./cm. ³	<i>V</i> , cc.	<i>a</i> , cm.
0.0	0.0	0.0	0.0	0.0	..
10.0	6.3	0.65	1.3	8.7	2.9
15.0	9.7	0.85	2.2	12.8	3.05
20.0	13.4	1.05	3.4	16.6	3.11
30.0	21.0	1.45	6.0	24.0	3.13
35.0	24.85	1.60	7.35	27.65	3.19
40.0	28.65	1.75	8.65	31.35	3.22
45.0	32.35	2.05	10.1	34.9	3.12

Av. 3.16

b = buret reading; *m* = manometer reading; buret cross section, 2 cm.²; *p* = *m* - *b*/2; *V* = *b* - *p*; from the equation $V = \frac{1}{6} [\pi h (3a^2 + h^2)]$, $a = \sqrt{\frac{2V}{\pi h} - \frac{h^2}{3}}$; average, *a* = 3.16; *a*² = 10.

To determine the influence of gravity on the results, tests were made with duplicate samples, running one with the bell vertically upward

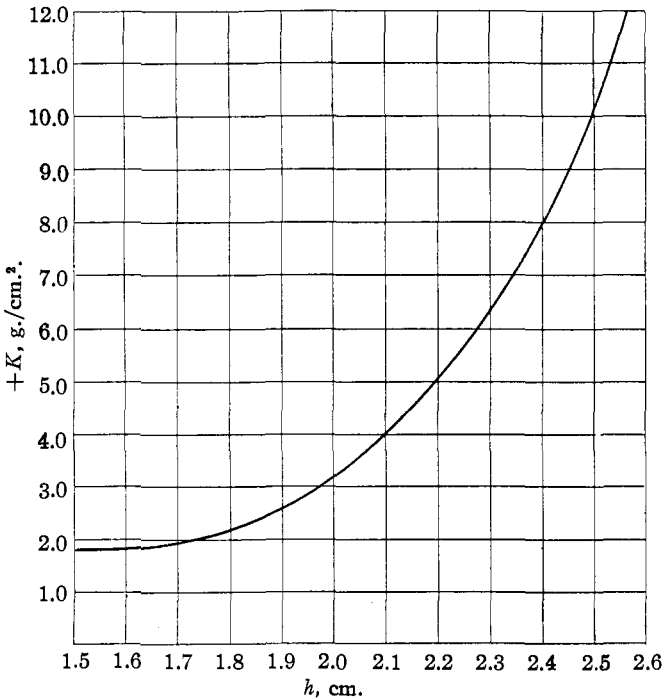

d = 0.2 cm.; 20% jelly, $\rho = 1.055$.

Fig. 5.

and the other downward. The result is shown in Table II and Fig. 4. The error due to gravity was eliminated by taking the mean of the two

curves. Fig. 5 shows the corrections to be made when the bell is held in a downward position with a membrane thickness of 0.2 cm. and gelatin

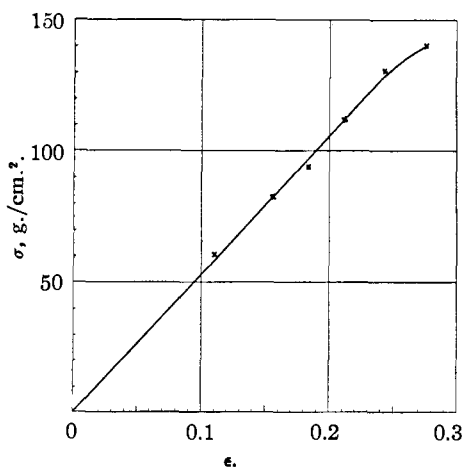

Fig. 6.

concentration of 20%. The correction K_1 for membranes of thickness d and density δ is

$$K_1 = K \frac{\delta d}{1.055 \times 0.2} = K \frac{\delta d}{0.211} \quad (8)$$

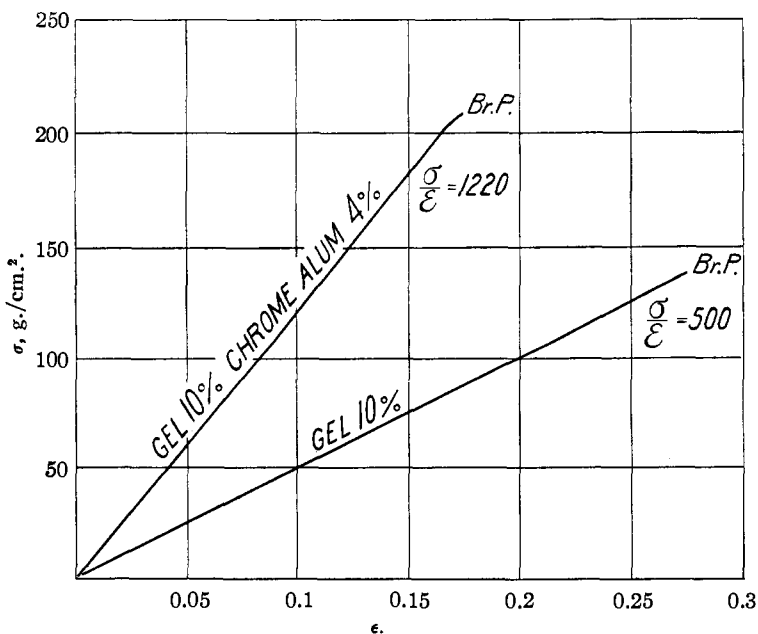

Fig. 7.

The value of a in the present experiments was determined for membranes from 0.2–0.3 cm. thick. For thicker or thinner membranes a new a value should be determined.

The following experiments showing the application of this method have been corrected for the effect of gravity.

Fig. 6 and Table III show the results of a test on "Silver Label" gelatin. Fig. 7 shows the effect of chrome alum on the same gelatin.

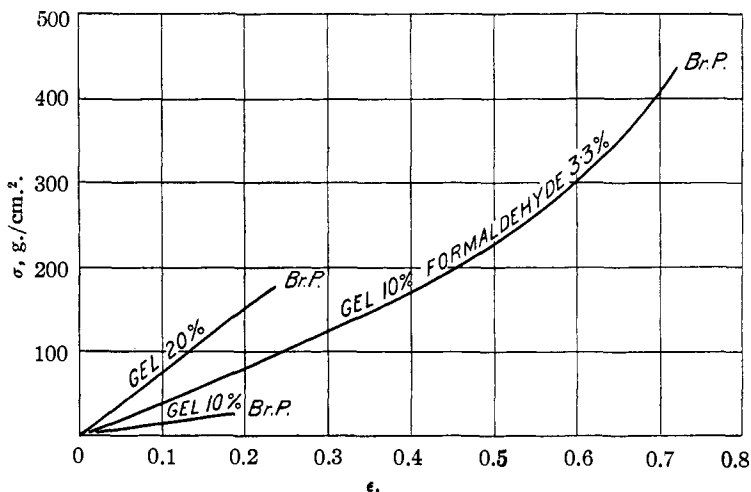

Fig. 8.

Fig. 8 shows the effect up to the breaking point, Br. P., of formaldehyde on Eastman gelatin P 1099. It is interesting to note that chrome alum does not change the character of the elasticity curve while formaldehyde produces a curve closely resembling rubber.

TABLE II
EFFECT OF GRAVITY

Eastman gelatin, P 1099; 20% jelly; twenty-four hours' setting; room temperature; $d = 0.2$ cm.; $c = 0.125$.

b	m	p , g./cm. ²	V , cc.	h , cm.	X	ϵ	σ , g./cm. ²
30.0	21.3	6.3	23.7	1.5	100.0	0.105	78.75
40.0	29.2	9.2	30.8	1.825	97.5	.148	112.10
45.0	33.0	10.5	34.5	1.95	98.0	.170	128.65
50.0	36.8	11.8	38.2	2.15	99.5	.200	146.75
55.0	40.6	13.1	41.9	2.3	101.5	.230	166.2

Bell vertically downward.

30.0	21.6	6.6	23.4	1.45	101.0	0.098	80.0
40.0	29.5	9.5	30.5	1.8	97.5	.145	115.8
45.0	33.35	10.85	34.15	1.95	98.0	.170	133.0
50.0	37.2	12.2	37.8	2.1	99.0	.195	151.0
55.0	41.2	13.7	40.3	2.25	101.0	.220	173.0

Bell vertically upward.

TABLE III
TEST ON "SILVER LABEL" GELATIN

b	m	p , g./cm. ²	V , cc.	h , cm.	X	ϵ	σ , g./cm. ²	$+K_1$	σ , g./cm. ² , corr.
31.0	21.05	5.55	25.45	1.55	99.5	0.110	58.5	1.9	60.4
40.0	27.7	7.7	32.3	1.875	98.5	.157	80.4	1.9	82.3
44.0	30.65	8.65	35.35	2.025	98.0	.183	89.8	3.5	93.3
50.0	35.00	10.00	40.00	2.225	100.05	.215	106.05	5.7	111.75
55.0	38.60	11.10	43.9	2.4	103.5	.243	121.8	8.8	130.6
60.0	42.0	12.0	48.0	2.55	106.5	.275	127.8	12.1	139.9

Gelatin, "Silver Label;" 10% jelly; twenty hours' setting; room temperature; $d = 0.235$ cm.; $c = 0.106$; $\delta = 1.03$; $K_1 = 1.1$ K.

TABLE IV

DENSITY OF GELATIN JELLIES ^a			
Concn., %	Gelatin α	Sp. gr.	Gelatin β
5		1.014	5
10		1.028	10
20		1.054	20
30		1.088	30
40		1.122	40
50		1.166	50

^a P. Bary, "Les Colloides," Dunod, Paris, 1921, p. 42.

In calculating the tensile strength, the actual thickness of the membrane at the moment the readings are taken is used and not the original thickness, as in most previous work on this subject.

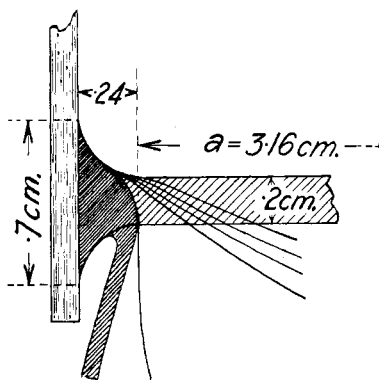

Fig. 9.

slightly as h increases. When h is less than 3 cm. no correction need be made.

Summary

An apparatus and method for studying the elastic properties of gelatin jellies under static loading conditions are described.

The apparatus can be used to study the time of relaxation of stretched membranes.

The method is applicable to the study of any elastic medium that can be formed into a membrane.

The influence of chrome alum and formaldehyde on gelatin jellies is shown.

JERSEY CITY, N. J.

[CONTRIBUTION FROM THE CHEMICAL LABORATORY OF THE UNIVERSITY OF CALIFORNIA
AT LOS ANGELES]

THE VAPOR PRESSURES OF POTASSIUM AMALGAMS

BY RUSSELL W. MILLAR

RECEIVED JULY 30, 1927

PUBLISHED DECEMBER 10, 1927

According to the freezing point-composition curves of the amalgams of the alkali and alkaline earth metals,¹ these solutions should possess properties far different from those of the ideal solution. This assumption is confirmed by the vapor-pressure and electromotive-force measurements of several investigators.²

On account of the ease of distillation and availability of metallic potassium, its amalgams were chosen for study as examples of extremely imperfect solutions.

The method was that of Ramsay, which has been used by practically all investigators in this field. A closed J-tube was filled with the amalgam and thoroughly boiled out *in vacuo*, so that the short, closed arm contained no gas. The amalgam was then brought to a constant temperature and the pressure of the mercury vapor in the closed arm was balanced by that of hydrogen in the long arm. The pressure of the hydrogen was measured by means of a manometer. The fine adjustment of the hydrogen pressure was accomplished by means of a narrow barometric column as used by Hildebrand in his measurements of the vapor pressures of zinc amalgams.³

Apparatus.—The J-tube was of heavy-walled Pyrex tubing of 0.70 cm. internal diameter. The short arm was 3–4 cm. in length. The temperature was maintained by means of a well-insulated air-bath in which the temperature was kept uniform by means of a fan. Windows permitted observation of the amalgam. The voltage of the lighting circuit by which the oven was heated varied considerably, but it was found that equilibrium was attained so rapidly that the readings obtained fell upon the same curve whether the temperature was rising or falling.

The temperature was measured by means of a nichrome-constantan thermocouple

¹ (a) Jänecke, *Z. physik. Chem.*, **57**, 510 (1907). (b) Smits and Beck, *Proc. Acad. Sci. Amsterdam*, **23**, 975 (1921).

² (a) Ramsay, *J. Chem. Soc.*, **55**, 521 (1889). (b) Meyer, *Z. physik. Chem.*, **7**, 477 (1891). (c) Schoeller, *Z. Elektrochem.*, **5**, 259 (1898). (d) von Wartenberg, *ibid.*, **20**, 443 (1914). (e) Eucken and Neumann, *ibid.*, **28**, 322 (1922). (f) Fay and North, *Am. Chem. J.*, **25**, 216 (1901). (g) Beckmann and Liesche, *Z. anorg. Chem.*, **89**, 171 (1914). (h) Beck, *Rec. trav. chim.*, **41**, 353 (1922).

³ Hildebrand, *Trans. Am. Electrochem. Soc.*, **32**, 319 (1913).